

PRODUCTS CATALOGUE

Innovative Industrial Solutions



TABLE OF CONTENT

LABORATORY BENCHING SYSTEMS

1. Fixed Benching
2. Stem Benching
3. Height Adjustable Benching
4. Balance Benching

LABORATORY CABINETRY

5. Clip-On (Suspended)Cabinetry
6. MobileCabinetry
7. Bench Mounted (Regent Rack)

LABORATORY SERVICE SPINE SYSTEMS

8. Lab Work Stations
9. Wall Ducting (Electrical Panel)

FIXTURES, FITTINGS, FURNITURE AND EQUIPMENT

10. Polypropylene Sinks (Black)
11. Lab Taps
12. Eyewash Stations & Safety Showers
13. Accessories

Fume Control – Ducted Single / Double Sided

RACKING SYSTEMS

14. Steel Mazzanine
15. Metal Steel Pallets
 - Steel Metal Pallets
 - Steel Sump Tray
 - Steel Sheet Container Pallets
 - Steel Sheet Box Pallets
 - Collapsible Stacking Pallets
 - Cage Stacking Metal Pallets
 - Big Bag Metal Pallets
16. Industrial Racking System
 - Steel Mazzine Racking
 - Sloted Angle Racking
 - Steel Mesh Shelves Racking
 - Racking Pillar Crash Guard
 - Mobile Racking System
 - Drive In: Drive Out Racking
 - Racking System
 - Heavy Duty Pallets System
 - Cantiliver Racking



CABINETS

17. METAL Cabinets

- Gowning Cabinets
- Storage Cabinets

40

40

41

41

METAL LOCKERS

18. Metal Lockers

- Employee Lockers
- Executive Employee Lockers
- Executive Employee Lockers
- Pigeon Hole Lockers
- School Students Lockers

42

42

43

43

43

44

44



LABORATORY BENCHING SYSTEMS

FIXED BENCHING

The KN.Connect® Fixed benching system is precision-engineered to support hanging cabinetry. Its impervious surfaces and IP65-rated registered connections ensure compliance with PC2 standards, making it ideal for environments requiring a high level of containment. The design prioritises durability and adaptability for future-ready laboratories.



FEATURES

- PC2 Adjustable Stainless-Steel Feet
- With Capacity 400kg
- Cabinetry Hanging Rail For Modularity & Agility
- Chemical Resistance Phenolic
- Service Cavity at Back of Bench
- ChemTemp Extreme Benchtop

STANDARD COLOURS

Benchtop Colour

White light Gray



Frame Powder Coating

Pearl White GA078A



OPTIONS

- Powder Coating Colour
- Custom Length, Depth & Height
- Benchtop Material

SKU	Product	Height (mm)	Length (mm)	Depth (mm)
KNCONNECT250	Fixed Benching Small Full Bench	920	1150	750
KNCONNECT251	Fixed Benching Medium Full Bench	920	1500	750
KNCONNECT252	Fixed Benching Large Full Bench	920	1800	750
KNCONNECT253	Fixed Benching Small Extender Bench	920	1082	750
KNCONNECT254	Fixed Benching Medium Extender Bench	920	1432	750
KNCONNECT255	Fixed Benching Large Extender Bench	920	1732	750

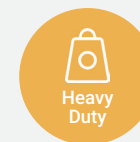



LABORATORY BENCHING SYSTEMS

STEM BENCHING

The mobile STEM range of benching offers a precision-engineered system that is widely used in science education laboratory settings. With impervious surfaces and IP65-rated connections, it meets PC2 standards, ensuring safety and durability in dynamic lab environments. Tough Chinese-made 100mm braked castors ensure longevity in harsh environments.

FEATURES

- With Capacity 400kg
- Chemical Resistance Phenolic
- ChemTemp Extreme Benchtop
- 105mm Chinese Made Braked Castors

STANDARD COLOURS

Benchtop Colour

White light Gray



Frame Powder Coating

Pearl White GA078A



OPTIONS

- Powder Coating Colour
- Custom Length, Depth & Height
- Benchtop Material



SKU	Product	Height (mm)	Length (mm)	Depth (mm)
KNCONNECT270	STEM Benching Small	920	1150	750
KNCONNECT271	STEM Benching Medium	920	1500	750
KNCONNECT272	STEM Benching Large	920	1800	750

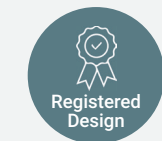
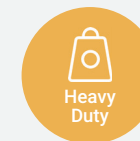



LABORATORY BENCHING SYSTEMS

HEIGHT ADJ. BENCH

The KN.Connect® Height-adjustable benching system is precision-engineered to facilitate both heavy equipment and physical containment level 2 requirements. With a range from 650 – 1150mm the benching is widely used for DDA, ergonomic, and equipment use.

FEATURES

- With Capacity 400kg
- ChemTemp Extreme Benchtop

OPTIONS

- Custom Length, Depth & Height
- Benchtop Material
- 105mm Chinese Made Braked Castors
- Standard or Ergoswiss designs



STANDARD COLOURS

Benchtop Colour

White

light Gray



Frame Powder Coating

Pearl White

GA078A



Aluminium-
Finish



ERGOSWISS SKU	Product	Height (mm)	Length (mm)	Depth (mm)
KNCONNECT480	Height Adjustable Benching Small	650-1150	1150	750
KNCONNECT481	Height Adjustable Benching Medium	650-1151	1500	750
KNCONNECT482	Height Adjustable Benching Large	650-1152	1800	750
ERGOSWISS SKU	Product	Height (mm)	Length (mm)	Depth (mm)
KNCONNECT489	Height Adj. Benching Small Ergoswiss	705-1185	1150	750
KNCONNECT490	Height Adj. Benching Medium Ergoswiss	705-1185	1500	750
KNCONNECT491	Height Adj. Benching Large Ergoswiss	705-1185	1800	750



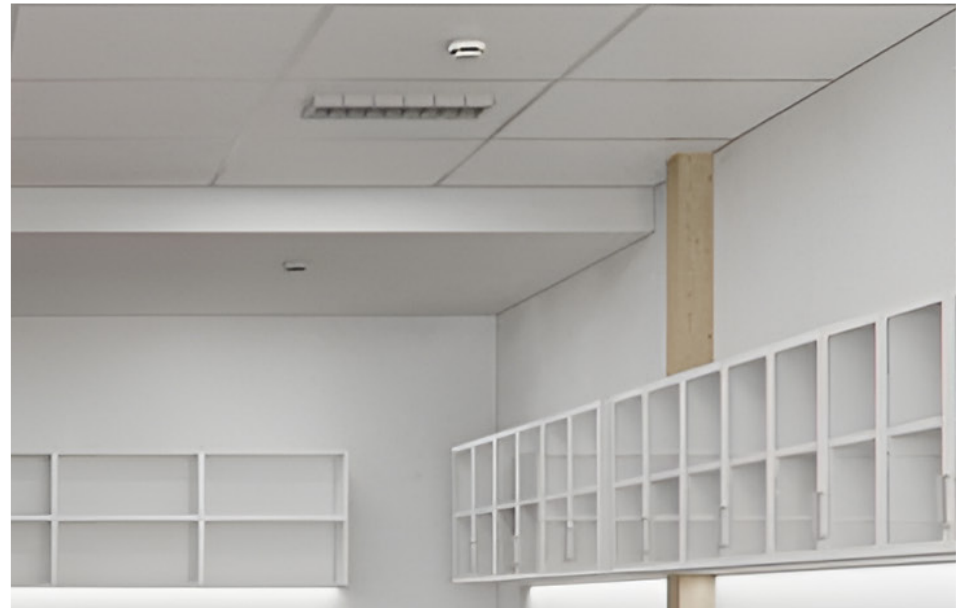

LABORATORY BENCHING SYSTEMS

BALANCE BENCHING

The KN.Connect® balance benching has been design to minimise vibration through anti-vibration mounts along with a sturdy frame and 80mm stone benchtop. Its impervious surfaces and IP65-rated registered connections ensure compliance with PC2 standards.

FEATURES

- Qualicoat High Durability Powder Coat Finish
- With Capacity 400kg
- PC2 Adjustable
- Stainless-Steel Feet
- Service Cavity at Back of Bench

OPTIONS

- Custom Length, Depth & Height
- Powder Coating Colour

STANDARD COLOURS

Benchtop Colour

Black

Gray



Frame Powder Coating

Pearl White

GA078A

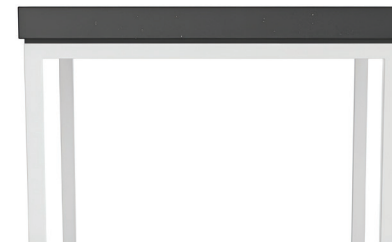

SKU	Product	Height (mm)	Length (mm)	Depth (mm)
KNCONNECT280	Balance Benching Small	920	750	750
KNCONNECT281	Balance Benching Medium	920	900	750
KNCONNECT282	Balance Benching Large	920	1150	750



LABORATORY CABINETRY

CLIP-ON (SUSPENDED) CABINETRY

The KN.Connect® Clip-On cabinetry is fully ABS edged including hidden edges. The customer-centric design allows users to clip on cabinetry to the KN Connect® fixed benching system with precision and ease. Carefully engineered fixtures and fittings ensure compliance to physical containment level 2. Configurations include open shelving, cupboards, drawers and Grattells trays.

FEATURES

- Customize
- 13mm Commercial Laminate
- Handle Type: Aluminium
- **ABS** Edging all around (All Edges are Arise Edged)

OPTIONS

- Custom Material
- Custom Colour
- Custom Style
- Custom Length, Depth & Height

STANDARD COLOURS

Commercial Polar White



SKU	Product	Height (mm)	Length (mm)	Depth (mm)
KNCONNECT290	Clip-On Cabinetry 360 Wide 1 Door	660	360	610
KNCONNECT291	Clip-On Cabinetry 360 Wide Grattells	660	360	610
KNCONNECT292	Clip-On Cabinetry 360 Wide 2 Drawer	660	360	610
KNCONNECT293	Clip-On Cabinetry 360 Wide 3 Drawer	660	360	610
KNCONNECT294	Clip-On Cabinetry 360 Wide 4 Drawer	660	360	610
KNCONNECT295	Clip-On Cabinetry 650 Wide 2 Door	660	650	610
KNCONNECT296	Clip-On Cabinetry 650 Wide Open 1 Shelf	660	650	610
KNCONNECT297	Clip-On Cabinetry 650 Wide 2 Drawer	660	650	610
KNCONNECT298	Clip-On Cabinetry 650 Wide 3 Drawer	660	650	610
KNCONNECT299	Clip-On Cabinetry 650 Wide 4 Drawer	660	650	610
KNCONNECT300	Clip-On Cabinetry 1000 Wide 2 Door	660	1000	610
KNCONNECT301	Clip-On Cabinetry 1000 Wide Open 1 Shelf	660	1000	610
KNCONNECT302	Clip-On Cabinetry 1000 Wide 2 Drawer	660	1000	610
KNCONNECT303	Clip-On Cabinetry 1000 Wide 3 Drawer	660	1000	610
KNCONNECT304	Clip-On Cabinetry 1000 Wide 4 Drawer	660	1000	610



LABORATORY CABINETRY

MOBILE CABINETRY

The KN.Connect® Mobile cabinetry is fully ABS edged including hidden edges. The pre-fabricated modules allow for user-centric set up and flexibility. Carefully engineered fixtures and fittings ensure compliance to physical containment level 2. Configurations include open shelving, cupboards, drawers and Gragnell trays.



FEATURES

- Customize
- 13mm Commercial Laminate
- Handle Type: Aluminium
- **ABS** Edging all around (All Edges are Arise Edged)
- 105mm Lockable Castors

OPTIONS

- Custom Material (13mm Compact Laminate)
- Custom Colour
- Custom Style
- Custom Length, Depth & Height

STANDARD COLOURS

Commercial Polar White



SKU	Product	Height (mm)	Length (mm)	Depth (mm)
KNCONNECT320	Mobile Cabinetry 360 Wide 1 Door	801	360	590
KNCONNECT321	Mobile Cabinetry 360 Wide Gragnells	801	360	590
KNCONNECT322	Mobile Cabinetry 360 Wide 2 Drawer	801	360	590
KNCONNECT323	Mobile Cabinetry 360 Wide 3 Drawer	801	360	590
KNCONNECT324	Mobile Cabinetry 360 Wide 4 Drawer	801	360	590
KNCONNECT325	Mobile Cabinetry 650 Wide 2 Door	801	650	590
KNCONNECT326	Mobile Cabinetry 650 Wide Open 1 Shelf	801	650	590
KNCONNECT327	Mobile Cabinetry 650 Wide 2 Drawer	801	650	590
KNCONNECT328	Mobile Cabinetry 650 Wide 3 Drawer	801	650	590
KNCONNECT329	Mobile Cabinetry 650 Wide 4 Drawer	801	650	590
KNCONNECT330	Mobile Cabinetry 1000 Wide 2 Door	801	1000	590
KNCONNECT331	Mobile Cabinetry 1000 Wide Open 1 Shelf	801	1000	590
KNCONNECT332	Mobile Cabinetry 1000 Wide 2 Drawer	660	1000	590
KNCONNECT333	Mobile Cabinetry 1000 Wide 3 Drawer	801	1000	590
KNCONNECT334	Mobile Cabinetry 1000 Wide 4 Drawer	801	1000	590



LABORATORY CABINETRY

BENCH MOUNTED

(REGENT RACK)

The KN.Connect® bench mounted service spine is a fully extruded system that eliminates exposed fix points for physical containment level 2 compliance. The impervious extrusions come together with precision to make a seamless and compliant user centric service spine.

FEATURES

- Aluminium Extruded System
- Powder Coated Finish
- Removable Shelving
- Configurable

OPTIONS

- Incorporated Dimmable LED Strip Lighting
- Power, Data, Gas / Hydraulics
- Single or Double Shelf
- No LED Plain Shelf

STANDARD COLOURS

Frame Powder Coating

Pearl White
GA078A

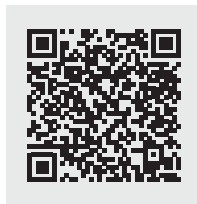

SKU	Product	Width (mm)	Length (mm)
KNCONNECT410	Bench Mounted B-Series Service Spine	708	> 3000





LABORATORY SERVICE SPINE SYSTEM

LAB WORK STATIONS

The KN.Connect® Lab work Stations offer the ultimate flexibility, with our service spine mounted on a mobile bench, providing modular access to essential utilities like power, data, and gases, while also offering ample bench space and overhead shelving.

FEATURES

- Aluminium Extruded System
- Powder Coated Finish
- Removable Shelving
- Configurable

OPTIONS

- Incorporated Dimmable **LED** Strip Lighting
- Power, Data, Gas / Hydraulics
- Single or Double Shelf
- No LED Plain Shelf

STANDARD COLOURS

Frame Powder Coating

Pearl White
GA078A

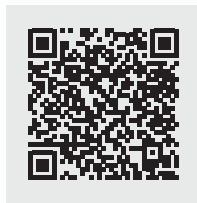

SKU	Product	Height (mm)	Length (mm)	Depth (mm)
KNCONNECT443	Small Full Bench	920	1150	750
KNCONNECT444	Medium Full Bench	920	1500	750
KNCONNECT445	Large Full Bench	920	1800	750





LABORATORY SERVICE SPINE SYSTEM

WALL DUCTING

(ELECTRICAL PANEL)

The KN.Connect® wall ducting is a fully extruded system that eliminates exposed fix points for compliance with physical containment level 2 standards. The impervious extrusions seamlessly form a compliant, user-centric service spine. Removable faceplates allow for additional services to be easily added or removed later.

FEATURES

- Aluminium Extruded System
- Removable Shelving
- Powder Coated Finish
- Configurable

OPTIONS

- Incorporated Dimmable **LED Strip Lighting**
- Power, Data, Gas / Hydraulics
- No **LED Plain Shelf**

STANDARD COLOURS

Frame Powder Coating

Pearl White
GA078A



SKU	Product	Height (mm)	Length (mm)	Depth (mm)
KNCONNECT450	Wall Ducting - Power/Data	124	6000	63
KNCONNECT451	Wall Ducting - Power/Data/Plain Shelf	222	330	
KNCONNECT452	Wall Ducting - Power/Data/LED Shelf	222	6000	330
KNCONNECT453	Wall Ducting - Gas	124	6000	63

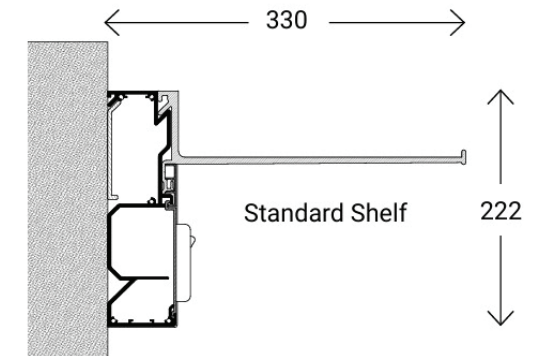
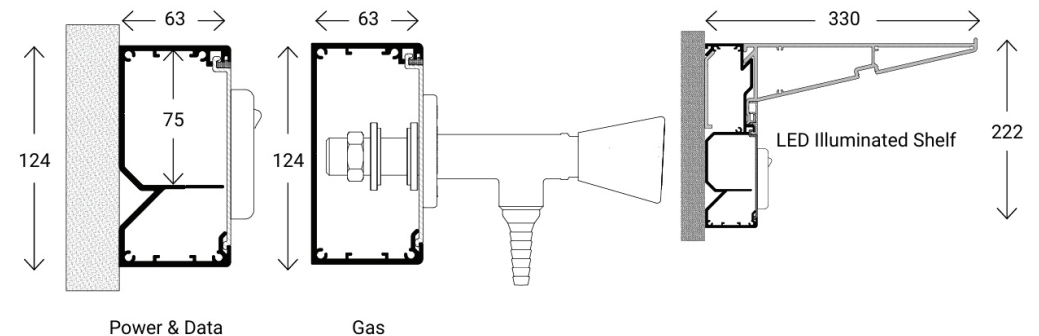



FIXTURES, FITTINGS, FURNITURE AND EQUIPMENT

POLYPROPYLENE (Imported) SINKS BLACK

Our black polypropylene (**imported**) undermounted lab sinks offer excellent chemical resistance, durability, and a sleek, easy-to-clean design, making them perfect for modern lab environments.

FEATURES

- Seamless undermount design
- Impact and heat resistant
- Sleek black matte finish
- Excludes plug and waste



SKU	Product	Height (mm)	Length (mm)	Depth (mm)
663-699	Laboratory Sink, PP, Black	310	550	450
663-874	Laboratory Sink, PP, With Over flow	310	550	450



SKU: 663-699



SKU: 663-874

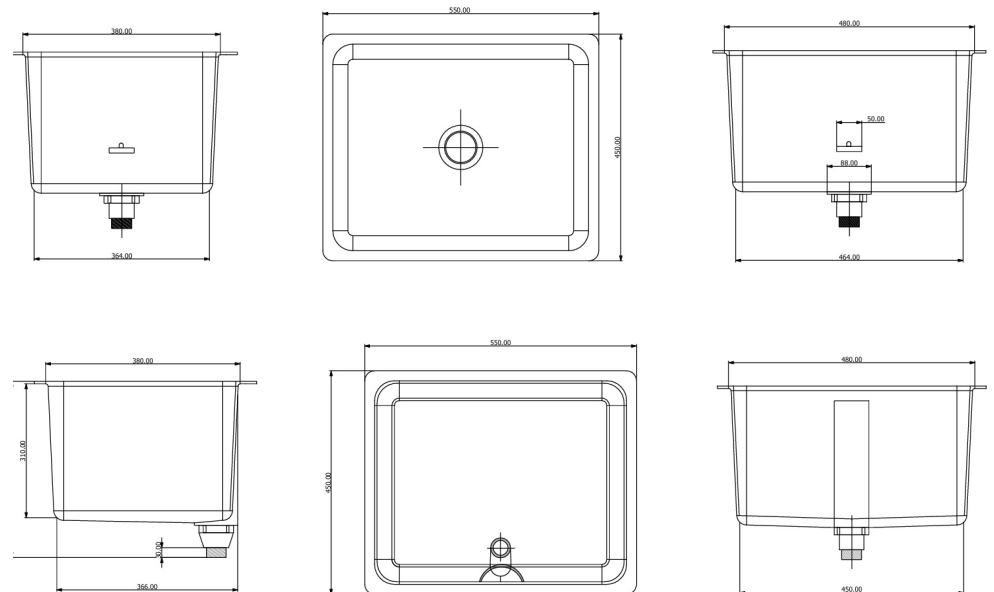



FIXTURES, FITTINGS, FURNITURE & EQUIPMENT

LAB TAPS

KN.fabrication Premium Laboratory Water Taps are engineered for bench mounting on a flat surface and are finished with an acid-resistant epoxy powder coating, providing robust surface protection. With a maximum working pressure of 10 bars, they are suitable for most laboratory conditions and applications, making them a versatile choice for various environments.

FEATURES

- Acid-resistant epoxy powder coated surface for durability
- **EPDM & ceramic** headwork sealing for reliable performance
- **AS/NZS3718:2005** water supply standard compliant
- Suitable for high-pressure applications of 10 bars
- Manufactured in Italy for quality



SKU: **663-699**



SKU: **663-874**

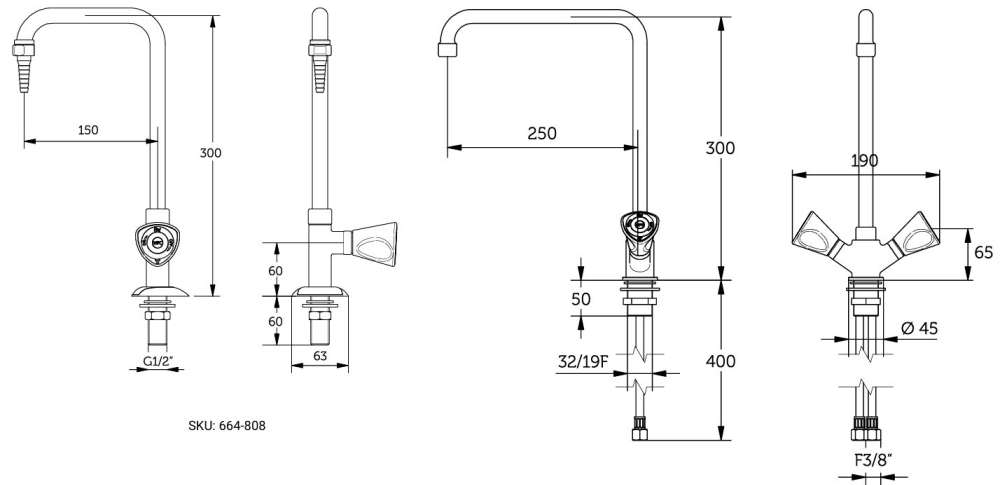

SKU: 664-808

SKU	Product	Test Pressure	Nominal Flow Rate
664-808	Bench Mounted, Single Water Tap, Swivel Spout	9 bars/air	5.2L/min
664-809	Bench Mounted, Mixer Water Tap, Single Hole, Swivel Spout	9 bars/air	5.3L/min



FIXTURES, FITTINGS, FURNITURE & EQUIPMENT

EYEWASH STATIONS & SAFETY SHOWERS

KN.fabrication Emergency Response range includes a variety of safety fixtures designed for laboratory environments, such as single-nozzle drench hoses, combination eye and body wash stations, and ceiling-mounted emergency showers.

FEATURES

- **Pressure Resistance:** Built to operate reliably under pressures up to 9 bars, ensuring robust performance in emergencies.
- **Flexible Installation Options:** Available in bench, wall, and ceiling-mounted models to suit different laboratory spaces.
- **Flow Rate Optimisation:** Configured with specific flow rates for safe, targeted decontamination of eyes and body
- **Durable and Safe Design:** Engineered for longevity and dependable use in laboratory environments.
- **AS/NZS3718:2005** water supply standard compliant
- Manufactured in Italy for quality

SKU	Product	Test Pressure	Nominal Flow Rate	Length (mm)	Depth (mm)	Height (mm)
664-810	Bench Mounted, Single Nozzle, Drench Hose	9 bars/air	7L/min max	65	65	240
664-811	Wall Mounted, Single Nozzle, Drench Hose	9 bars/air	120L/min (body wash)	65	65	240
664-812	Floor Mounted, Emergency Shower, Head & Eye Wash Combination	9 bars/air	14L/min (eye wash)	762	762	2150
664-813	Inset Wall Mounted, Emergency Eye Wash & Shower Combination	9 bars/air	14L/min max	505	100	425
664-815	Ceiling Mounted, Emergency Shower Outlet	-	75L/min max	65	65	560
664-816	Inset Wall Mounted, Emergency Eye Wash	9 bars/air	14L/min max	305	100	425
664-817	Inset Wall Mounted, Emergency Shower Valve	9 bars/air	60L/min at 1 bar flow pressure	220	60	350



FIXTURES, FITTINGS, FURNITURE & EQUIPMENT

ACCESSORIES

At KN.fabrication, we offer a comprehensive range of fixtures and equipment, catering to all your laboratory needs, and providing the complete solution to equip your workspace for success. Most are in stock in our Pakistani warehouses, ready for same day despatch.

LAB COAT RACK

The Heavy Duty Z Rack features chrome uprights and crossbar for durability and a sleek appearance. The rack is supported by a sturdy black sand heavy-duty 'Z' base, designed to evenly distribute weight for stability.

FEATURES

- Lockable, heavy-duty castors for manoeuvrability
- Maximum capacity of 50kg to 60kg
- Quick and easy assembly
- Flat packed for transport

SKU	Product	Height (mm)	Length (mm)	Depth (mm)
012120-3000	Lab Coat Z-Rack, Lockable Castors	1735	1555	555
WJH0362A	Lab Draining Rack, Wall Mounted, 52 Slots, Grey	700	550	120

LAB COAT RACK

Peg sockets secure to the rack with a push-and-lower mechanism for improved load-bearing, and pegs are easily removable for cleaning or rearrangement.

The bracket's sloped design ensures seamless liquid drainage through the built-in outlet, with an included hose for rear draiage. Two racks can be combined to form a double sided benchtop draining rack.

FEATURES

- Polypropylene (**imported**) single-side draining rack
- Flat packed for transport





These hoods safely channel harmful chemical vapors out of the building, ensuring a secure and pleasant work environment, and are EN-14175 / CE / ASHRAE 110-1995 certified for use with heavy chemicals.

FUME CONTROL – SINGLE / DOUBLE SIDED

DUCTED FUME CABINET SINGLE / DOUBLE SIDED

The KN.Connect® Polypropylene (**imported**) Fume Hoods are made from high-quality, non-corrosive polypropylene (**imported**), offering excellent chemical resistance against acids, bases, gases, and organic solutions. Manufactured in Pakistan using metal and stainless steel, they come with a sales pack and are customizable to meet specific needs.

FEATURES

- 8 mm welded polypropylene (**imported**) construction for superior chemical resistance.
- Polypropylene (**imported**) worktop.
- 5 mm front safety glass window equipped with a counterweight system for easy operation.
- Lower vented base cabinet constructed from durable polypropylene (**imported**).
- Dual air ventilation system, providing airflow from both the top and rear panels.
- Active control system: 10.1" screen with energy saver, automatic sash motion and proximity sensing system.
- 800 lux LED lighting separated from the work area.
- Pot sinks and cold water tap and power GPO outlets.

OPTIONS

- Gas outlets
- Custom Design
- Integrated Wet Scrubber module

SKU	Product	Height (mm)	Width (mm)	Depth (mm)
665-810	Ducted Fume Cabinet 900	2320	900	830
665-811	Ducted Fume Cabinet 1200	2320	1200	830
665-812	Ducted Fume Cabinet 1500	2320	1500	830
665-813	Ducted Fume Cabinet 1800	2320	1800	830
665-814	Ducted Fume Cabinet 2000	2320	2000	830

SKU	Product	Height (mm)	Width (mm)	Depth (mm)
665-815	Ducted Fume Cabinet 900 (Double Sided)	2320	900	830
665-816	Ducted Fume Cabinet 1200 (DS)	2320	1200	830
665-817	Ducted Fume Cabinet 1500 (DS)	2320	1500	830
665-818	Ducted Fume Cabinet 1800 (DS)	2320	1800	830
665-819	Ducted Fume Cabinet 2000 (DS)	2320	2000	830

SKU	Product	Height (mm)	Width (mm)	Depth (mm)
665-820	Ducted Fume Cabinet 1200 + Scrubber	2320	1200	830
665-821	Ducted Fume Cabinet 1500 + Scrubber	2320	1500	830
665-822	Ducted Fume Cabinet 1800 + Scrubber	2320	1800	830
665-823	Ducted Fume Cabinet 2000 + Scrubber	2320	2000	830



RACKING SYSTEM

STEEL MEZZANINE

Maximize Your Space with Strength and Versatility

Maximize your space with our premium Steel Mezzanines, expertly designed to offer unmatched durability, functionality, and exceptional load-bearing capacity. Ideal for warehouses, industrial facilities, retail environments, and commercial spaces across Pakistan, these mezzanines enable you to utilize vertical space effectively, creating additional floors without extensive construction or high costs. Manufactured with high-grade steel and advanced engineering, they deliver superior strength, stability, and long-term reliability, even under the most demanding conditions. Fully customizable to meet your specific requirements for size, design, and finish, our steel mezzanines are the perfect solution for expanding storage, improving workflows, or creating additional workspaces. With cutting-edge technology and precision manufacturing, these mezzanines combine innovation, practicality, and premium quality to help elevate your business operations across Pakistan.



At Racks.com.pk, we are driven by a commitment to excellence and customer satisfaction. Each product we create reflects our passion for designing efficient, durable, and space-saving solutions that cater to the diverse needs of businesses in Pakistan.

Today, Racks.com.pk is proud to be a trusted partner for businesses across industries throughout Pakistan, transforming spaces into organized, productive environments. Built on a foundation of trust, quality, and innovation, our journey is dedicated to making storage solutions in Pakistan smarter, stronger, and simpler.



METAL - STEEL PALLETs

Durable and Reliable Metal-Steel Pallets in Pakistan

Optimize your storage and logistics operations with our top-quality Metal-Steel Pallets, designed to deliver unmatched strength, durability, and reliability. Perfect for warehouses, industrial facilities, and transportation needs in Pakistan, these pallets are built to handle heavy loads effortlessly, ensuring superior performance in even the toughest environments. Crafted from high-quality, corrosion-resistant steel, our Metal-Steel pallets guarantee long-lasting stability, resistance to wear and tear, and excellent cost-effectiveness over time. Available in various sizes and fully customizable options, these Metal-Steel Pallets offer the ideal solution for efficient load handling, storage optimization, and safe transport. With precision engineering and an exceptional strength-to-weight ratio, they ensure your operations across Pakistan run smoothly, securely, and with minimal downtime.

Product Category



Steel-Metal Pallet

Optimize storage efficiency with steel-metal pallets, designed for durability, adaptability, and seamless handling of inventory.



Steel Sump Tray

Optimize liquid containment and safety with steel sump trays, designed for durability, versatility, and efficient spill management.



Steel Sheet Container Pallet

Enhance your storage efficiency with steel sheet container pallets, designed for durability, adaptability, and seamless organization of goods.



Steel Sheet Box Pallet

Optimize your storage solutions with steel sheet box pallets, designed for durability, adaptability, and seamless handling of goods.



Collapsible Stacking Pallet

Optimize your storage solutions with collapsible stacking pallets, designed for durability, adaptability, and seamless handling of inventory.



Cage - Stacking Metal Pallets

Enhance storage efficiency with durable cage-stacking metal pallets, designed for robust performance, adaptability, and seamless inventory management.



Big Bag Metal Pallet

Enhance storage efficiency with durable Big Bag Metal Pallets, designed for versatility, robust load support, and seamless handling of materials.



INDUSTRIAL RACKING SYSTEMS

Industrial Racking Systems in Pakistan: Optimize Space and Efficiency

Enhance your storage capacity and streamline workflows with our durable industrial Racking Systems in Pakistan. Designed to meet the demanding needs of warehouses, distribution centers, and manufacturing facilities, these racking solutions are built to handle heavy-duty use. Constructed with premium-quality materials, they provide unmatched strength, long-lasting durability, and fully customizable configurations tailored to your specific requirements. Whether you need adjustable shelving, selective racking, or advanced



automated systems, our industrial racking solutions ensure easy access, improved organization, and enhanced productivity. Engineered to withstand heavy loads, they are the ideal choice for maximizing floor space while securely managing your inventory. At Racks.com.pk, we are committed to excellence and customer satisfaction. Every product we create reflects our dedication to offering efficient, durable, and space-saving storage solutions to businesses across Pakistan.

Product Category



Steel Mezzanine Racking

Enhance your storage solutions with steel mezzanine racking, designed for durability, adaptability, and efficient organization of your inventory.



Steel Mesh Shelf Racking

Optimize your storage solutions with steel mesh shelf racking, crafted for durability, adaptability, and seamless organization of your inventory.



Slotted Angle Racking

Optimize your storage with slotted angle racking systems designed for durability, adaptability, and seamless organization of your inventory.



Racking Pillar Crash Guard

Protect your storage solutions with robust racking pillar crash guards, designed for durability, adaptability, and seamless safeguarding of inventory access points.



Mobile Racking System

Optimize your storage efficiency with mobile racking systems, designed for durability, adaptability, and seamless inventory management.



Heavyduty Pallet System

Enhance your storage solutions with a heavy-duty pallet system designed for durability, adaptability, and seamless inventory handling.



Drive in:Drive out Racking

Enhance your warehouse operations in Pakistan with our Drive In and Drive Out Racking System, specifically designed for high-density storage & optimal space utilization.



Cantiliver Racking

Enhance storage efficiency with cantilever racking systems, designed for exceptional durability, adaptability, and seamless access to long or bulky materials.



Racking System

Boost storage efficiency with racking systems designed for durability, adaptability, & seamless inventory management.



METAL CABINETS

KN Fabrication specializes in manufacturing custom metal cabinets for industrial, commercial, and storage applications. Their cabinets are known for high durability, precision engineering, and secure storage solutions.

Features of Metal Cabinets:

Material: High-quality steel, stainless steel, or aluminum.

Customization: Available in various sizes, designs, and finishes based on industry needs.

Heavy-Duty Build: Strong, reinforced structure for industrial environments.

Security: Lockable doors with advanced locking mechanisms.

Storage: Adjustable shelves, drawers, pegboards, and compartments for efficient tool organization.

Mobility: Some models include caster wheels for easy movement.



Product **Category**



Gowning Cabinets

Gowning cabinets provide hygienic storage for protective garments in cleanrooms, labs, and healthcare facilities, preventing contamination & ensuring compliance.



Storage Cabinets

Storage cabinets provide secure and organized storage for tools, equipment, and supplies in various industries. Ideal for offices, warehouses, labs, health-care, and industrial use.



METAL LOCKERS

KN. Fabrications is a prominent Pakistani manufacturer specializing in high-quality metal and storage solutions. Our metal lockers are meticulously designed to provide secure and organized storage across various environments, including workplaces, educational institutions, gyms, and more.

Features of Metal Lockers:

Security & Privacy: Protects personal belongings, tools, and documents with sturdy construction and lockable compartments.

Durability: Made from heavy-duty steel, resistant to wear, impact, and corrosion, ensuring long-term use.

Space Optimization: Maximizes storage efficiency in offices, schools, gyms, and industrial spaces.

Ventilation & Hygiene: Perforated designs or louvers allow airflow, preventing odor and moisture buildup.

Customization & Versatility: Available in various sizes, tiers, and locking mechanisms to suit different needs.

Enhanced Organization: Helps maintain clutter-free and organized spaces for users.

Product Category



Employee Lockers

Designed for secure storage of personal belongings, work gear, and uniforms, promoting an organized workplace.



Executive Employee Lockers

Tailored for management staff, offering sophisticated designs with additional features like luxurious finishes and extra compartments.



Gym Dressing Room Lockers

Specifically designed for gyms and fitness centers, these lockers provide secure storage for members' belongings while withstanding high-traffic demands.



Pigeon Hole Lockers

Ideal for offices and mailrooms, offering efficient sorting and organization of mail, documents, and smaller personal items.



School Student Lockers

Designed with students in mind, providing secure storage for books, school supplies, and personal items, promoting an organized learning environment.



OUR CLIENTS



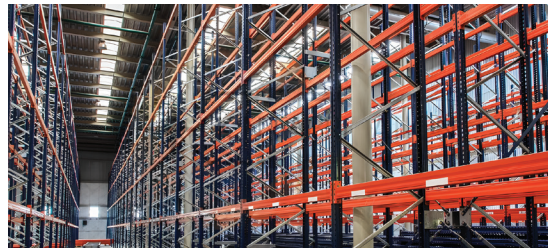
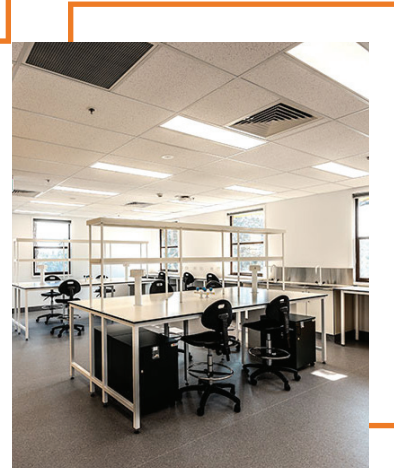

Contact Us

Knfabrications@gmail.com
Contact@knfabrication.com

• **Head Office Lahore**

0321-0009277
0321-0009377

Plot no: 5 main bagrian road
near kot lakh pat factory area
lahore pakistan

• **Website Links**

knfabrication.com
racks.com.pk
labfurniture.pk
laboratoryfurniture.pk
laboratory.furniture

